

# B系列短节距精密滚子链

## Short pitch precision roller chains (B series)

单排滚子链  
Simplex roller chains

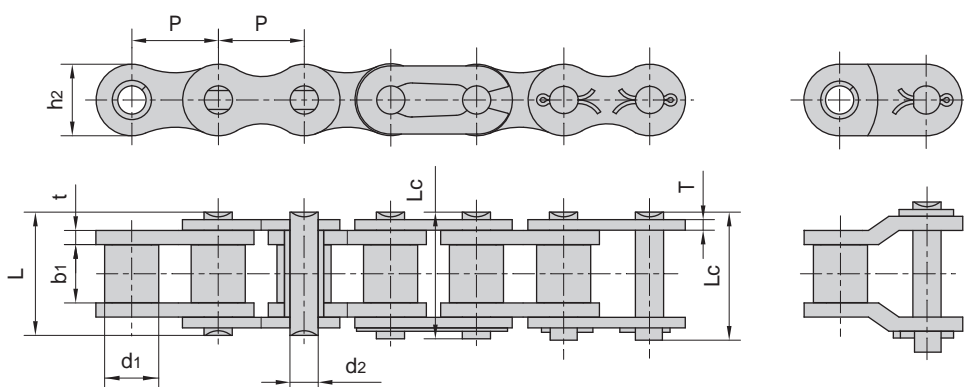

ISO 链号  ISO Chain No.	节距	滚子直径	内节内宽	销轴直径	销轴长度		内链板高度	链板厚度	极限拉伸载荷	平均拉伸载荷	每米长重
	Pitch	Roller diameter	Width between inner plates	Pin diameter	L	Lc	Inner plate depth	Plate thickness	Ultimate tensile strength	Average tensile strength	Weight per meter
	p	d1 max	b1 min	d2 max	L max	Lc max	h2 max	t/T max	Q min	Q0	q
	mm	mm	mm	mm	mm	mm	mm	mm	kN/bf	kN	kg/m
04B-1	6.000	4.00	2.80	1.85	6.80	7.8	5.00	0.60	3.0/682	3.2	0.11
05B-1	8.000	5.00	3.00	2.31	8.20	8.9	7.10	0.80	5.0/1136	5.9	0.20
*06B-1	9.525	6.35	5.72	3.28	13.15	14.1	8.20	1.30	9.0/2045	10.4	0.41
08B-1	12.700	8.51	7.75	4.45	16.70	18.2	11.80	1.60	18.0/4091	19.4	0.69
10B-1	15.875	10.16	9.65	5.08	19.50	20.9	14.70	1.70	22.4/5091	27.5	0.93
12B-1	19.050	12.07	11.68	5.72	22.50	24.2	16.00	1.85	29.0/6591	32.2	1.15
16B-1	25.400	15.88	17.02	8.28	36.10	37.4	21.00	4.15/3.1	60.0/13636	72.8	2.71
20B-1	31.750	19.05	19.56	10.19	41.30	45.0	26.40	4.50/3.5	95.0/21591	106.7	3.70
24B-1	38.100	25.40	25.40	14.63	53.40	57.8	33.20	6.00/4.8	160.0/36364	178.0	7.10
28B-1	44.450	27.94	30.99	15.90	65.10	69.5	36.70	7.50/6.0	200.0/45455	222.0	8.50
32B-1	50.800	29.21	30.99	17.81	66.00	71.0	42.00	7.00/6.0	250.0/56818	277.5	10.25
40B-1	63.500	39.37	38.10	22.89	82.20	89.2	52.96	8.50/8.0	355.0/80682	394.0	16.35
48B-1	76.200	48.26	45.72	29.24	99.10	107.0	63.80	12.00/10.0	560.0/127272	621.6	25.00
56B-1	88.900	53.98	53.34	34.32	114.6	123.0	77.80	13.50/12.0	850.0/193180	940.0	35.78
64B-1	101.600	63.50	60.96	39.40	130.0	138.5	90.17	15.00/13.0	112.0/254544	1240.0	46.00
72B-1	114.300	72.39	68.58	44.48	147.4	156.4	103.60	17.00/15.0	1400.0/318180	1550.0	60.80

\*直链板  
\*Straight side plates

# B系列短节距精密滚子链

## Short pitch precision roller chains (B series)

双排滚子链  
Duplex roller chains

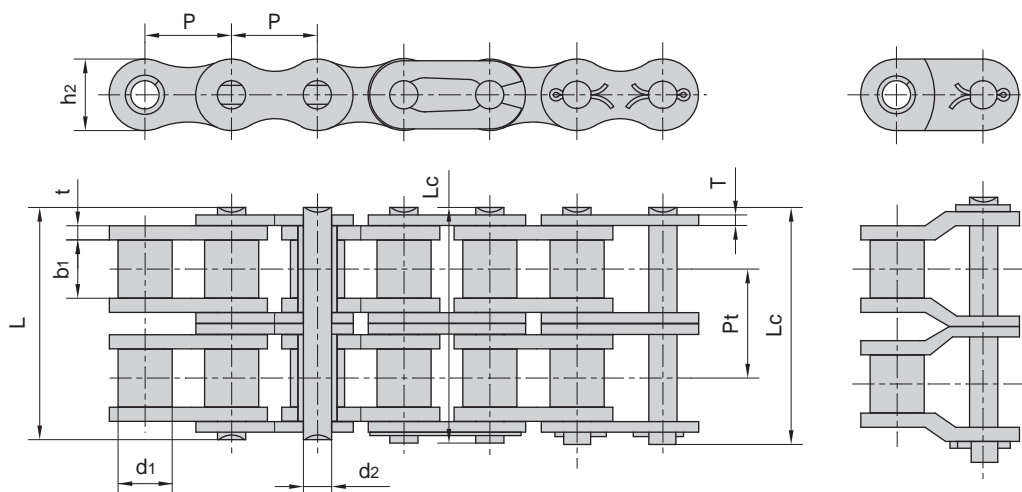

ISO 链号 ISO Chain No.	节距 Pitch	滚子直径 Roller diameter	内节内宽 Width between inner plates	销轴直径 Pin diameter	销轴长度 Pin length		内链板高度 Inner plate depth	链板厚度 Plate thickness	排距 Transverse pitch	极限拉伸载荷 Ultimate tensile strength	平均拉伸载荷 Average tensile strength	每米长重 Weight per meter
	P	d1 max	b1 min	d2 max	L max	Lc max	h2 max	t/T max	Pt	Q min	Q0	q
	mm	mm	mm	mm	mm	mm	mm	mm	mm	kN/bf	kN	kg/m
05B-2	8.000	5.00	3.00	2.31	13.9	14.5	7.10	0.80	5.64	7.8/1773	10.2	0.33
*06B-2	9.525	6.35	5.72	3.28	23.4	24.4	8.20	1.30	10.24	16.9/3841	18.7	0.77
08B-2	12.700	8.51	7.75	4.45	31.0	32.2	11.80	1.60	13.92	32.0/7273	38.7	1.34
10B-2	15.875	10.16	9.65	5.08	36.1	37.5	14.70	1.70	16.59	44.5/10114	56.2	1.84
12B-2	19.050	12.07	11.68	5.72	42.0	43.6	16.00	1.85	19.46	57.8/13136	66.1	2.31
16B-2	25.400	15.88	17.02	8.28	68.0	69.3	21.00	4.15/3.1	31.88	106.0/24091	133.0	5.42
20B-2	31.750	19.05	19.56	10.19	77.8	81.5	26.40	4.50/3.5	36.45	170.0/38636	211.2	7.20
24B-2	38.100	25.40	25.40	14.63	101.7	106.2	33.20	6.00/4.8	48.36	280.0/63636	319.2	13.40
28B-2	44.450	27.94	30.99	15.90	124.6	129.1	36.70	7.50/6.0	59.56	360.0/81818	406.8	16.60
32B-2	50.800	29.21	30.99	17.81	124.6	129.6	42.00	7.00/6.0	58.55	450.0/102273	508.5	21.00
40B-2	63.500	39.37	38.10	22.89	154.5	161.5	52.96	8.50/8.0	72.29	630.0/143182	711.9	32.00
48B-2	76.200	48.26	45.72	29.24	190.4	198.2	63.80	12.00/10.0	91.21	1000.0/227272	1130.0	50.00
56B-2	88.900	53.98	53.34	34.32	221.2	229.6	77.80	13.50/12.0	106.60	1600.0/363635	1760.0	71.48
64B-2	101.600	63.50	60.96	39.40	249.9	258.4	90.17	15.00/13.0	119.89	2000.0/454544	2200.0	91.00
72B-2	114.300	72.39	68.58	44.48	283.7	292.7	103.60	17.00/15.0	136.27	2500.0/568180	2750.0	120.40

\*直链板  
\*Straight side plates

# B系列短节距精密滚子链

## Short pitch precision roller chains (B series)

三排滚子链  
Triplex roller chains

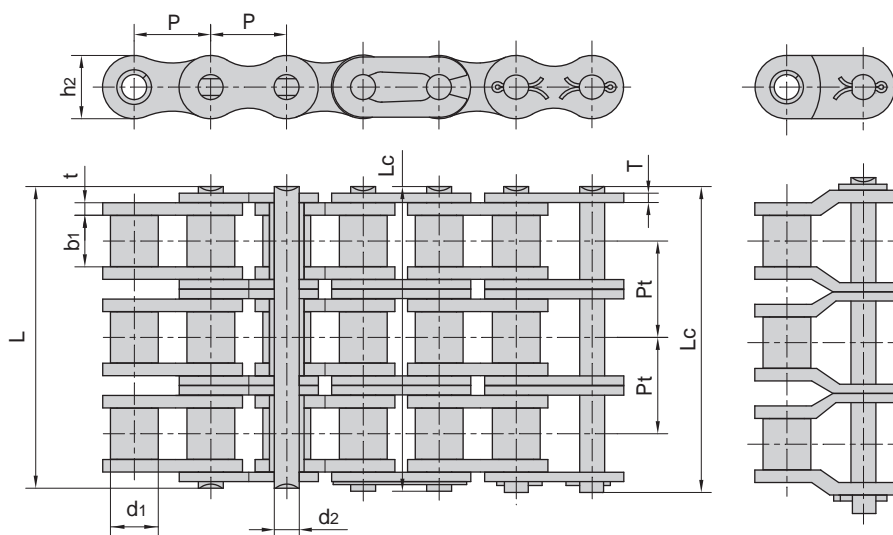

ISO 链号 ISO Chain No.	节距	滚子直径	内节内宽	销轴直径	销轴长度		内链板高度	链板厚度	排距	极限拉伸载荷	平均拉伸载荷	每米长重
	Pitch	Roller diameter	Width between inner plates	Pin diameter	L	Lc	Inner plate depth	Plate thickness	Transverse pitch	Ultimate tensile strength	Average tensile strength	Weight per meter
	P	d1 max	b1 min	d2 max	L max	Lc max	h2 max	t/T max	Pt	Q min	Q0	q
	mm	mm	mm	mm	mm	mm	mm	mm	mm	kN/lbf	kN	kg/m
05B-3	8.000	5.00	3.00	2.31	19.5	20.2	7.10	0.80	5.64	11.1/2523	13.8	0.48
*06B-3	9.525	6.35	5.72	3.28	33.5	34.6	8.20	1.30	10.24	24.9/5659	30.1	1.16
08B-3	12.700	8.51	7.75	4.45	45.1	46.1	11.80	1.60	13.92	47.5/10795	57.8	2.03
10B-3	15.875	10.16	9.65	5.08	52.7	54.1	14.70	1.70	16.59	66.7/15159	84.5	2.77
12B-3	19.050	12.07	11.68	5.72	61.5	63.1	16.00	1.85	19.46	86.7/19705	101.8	3.46
16B-3	25.400	15.88	17.02	8.28	99.8	101.2	21.00	4.15/3.1	31.88	160.0/36364	203.7	8.13
20B-3	31.750	19.05	19.56	10.19	114.2	117.9	26.40	4.50/3.5	36.45	250.0/56818	290.0	10.82
24B-3	38.100	25.40	25.40	14.63	150.1	154.6	33.20	6.00/4.8	48.36	425.0/96591	493.0	20.10
28B-3	44.450	27.94	30.99	15.90	184.2	188.7	36.70	7.50/6.0	59.56	530.0/120454	609.5	24.92
32B-3	50.800	29.21	30.99	17.81	183.2	188.2	42.00	7.00/6.0	58.55	670.0/152273	770.5	31.56
40B-3	63.500	39.37	38.10	22.89	226.8	233.8	52.96	8.50/8.0	72.29	950.0/215909	1092.5	48.10
48B-3	76.200	48.26	45.72	29.24	281.6	289.4	63.80	12.00/10.0	91.21	1500.0/340909	1710.0	75.00
56B-3	88.900	53.98	53.34	34.32	327.8	336.2	77.80	13.50/12.0	106.6	2240.0/545450	2464.0	107.18
64B-3	101.60	63.50	60.96	39.40	369.8	378.3	90.17	15.00/13.0	119.89	3000.0/681820	3300.0	136.00
72B-3	114.30	72.39	68.58	44.48	420.0	429.0	103.60	17.00/15.0	136.27	3750.0/852270	4125.0	180.00

\*直链板

\*Straight side plates