

双节距输送链

Double pitch conveyor chains

小滚子型 Small Roller Type

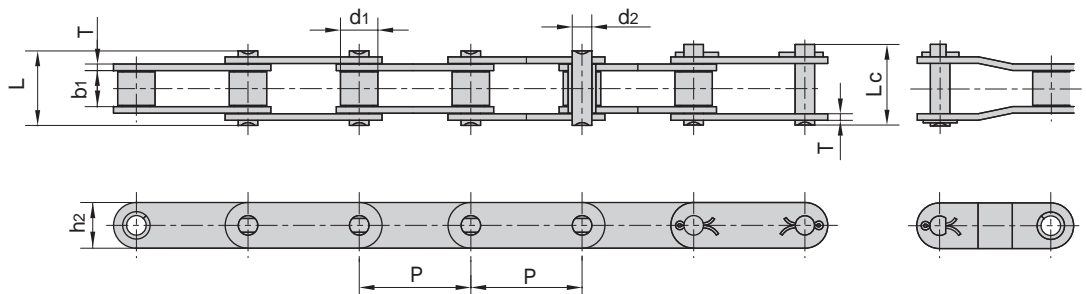

大滚子型 Large Roller Type

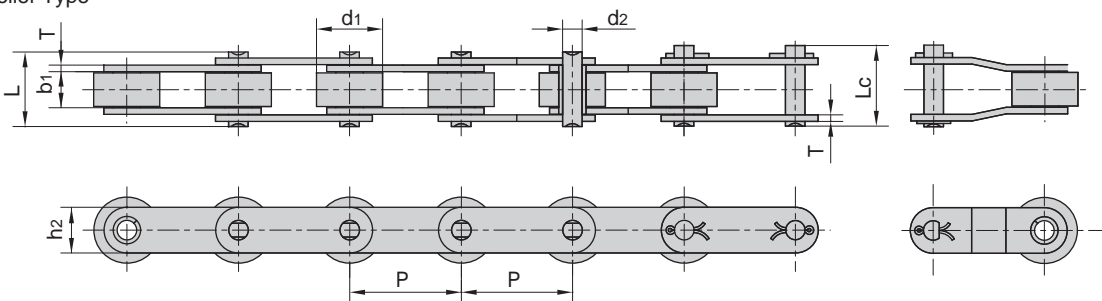

ISO 链号 ISO Chain No.	ANSI 链号 ANSI Chain No.	节距	滚子直径	内节内宽	销轴直径	销轴长度		内链板高度	链板厚度	极限拉伸载荷	平均拉伸载荷	每米长重
		Pitch	Roller diameter	Width between inner plates	Pin diameter	Pin length		Inner plate depth	Plate thickness	Ultimate tensile strength	Average tensile strength	Weight per meter
		P	d1 max	b1 min	d2 max	L max	Lc max	h2 max	T max	Q min	Q0	q
		mm	mm	mm	mm	mm	mm	mm	mm	kN/lbf	kN	kg/m
C208A C208AL	C2040 C2042	25.40	7.95 15.88	7.85	3.96	16.6	17.8	12.0	1.50	14.1/3205	16.7	0.50 0.84
C208AH	C2040H	25.40	7.95	7.85	3.96	18.8	19.9	12.0	2.03	14.1/3205	17.2	0.65
C208B C208BL		25.40	8.51 15.88	7.75	4.45	16.7	18.2	11.8	1.60	18.0/4091	19.4	0.55 0.89
C210A C210AL	C2050 C2052	31.75	10.16 19.05	9.40	5.08	20.7	22.2	15.0	2.03	22.2/5045	28.1	0.78 1.27
C212A C212AL	C2060 C2062	38.10	11.91 22.23	12.57	5.94	25.9	27.7	18.0	2.42	31.8/7227	36.8	1.12 1.61
C212AH C212AHL	C2060H C2062H	38.10	11.91 22.23	12.57	5.94	29.2	31.6	18.0	3.25	31.8/7227	41.6	1.44 2.07
C216A C216AL	C2080 C2082	50.80	15.88 28.58	15.75	7.92	32.7	36.5	24.0	3.25	56.7/12886	65.7	2.08 3.12
C216AH C216AHL	C2080H C2082H	50.80	15.88 28.58	15.75	7.92	36.2	39.4	24.0	4.00	56.7/12886	70.0	2.54 3.58
C220A C220AL	C2100 C2102	63.50	19.05 39.67	18.90	9.53	40.4	44.7	30.0	4.00	88.5/20114	102.6	3.01 4.83
C220AH C220AHL	C2100H C2102H	63.50	19.05 39.67	18.90	9.53	43.6	46.9	30.0	4.80	88.5/20114	112.4	3.56 5.38
C224A C224AL	C2120 C2122	76.20	22.23 44.45	25.22	11.10	50.3	54.3	35.7	4.80	127.0/28864	147.3	4.66 7.66
C224AH C224AHL	C2120H C2122H	76.20	22.23 44.45	25.22	11.10	53.5	57.5	35.7	5.60	127.0/28864	160.9	5.26 8.26
C232A C232AL	C2160 C2162	101.60	28.58 57.15	31.75	14.27	64.8	69.6	47.8	6.40	226.8/51545	278.9	8.15 13.00
C232AH C232AHL	C2160H C2162H	101.60	28.58 57.15	31.75	14.27	68.2	73.0	47.8	7.20	226.8/51545	285.8	9.06 13.84

双节距输送链

Double pitch conveyor chains

非标双节距输送链
Non-standard double pitch conveyor chains

小滚子型 Small Roller Type

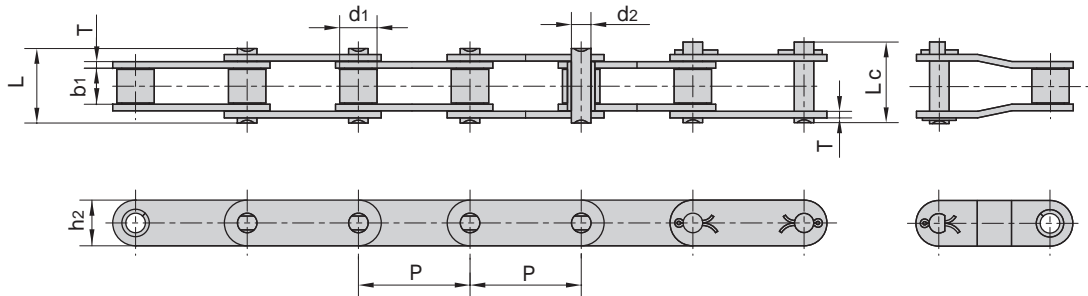

大滚子型 Large Roller Type

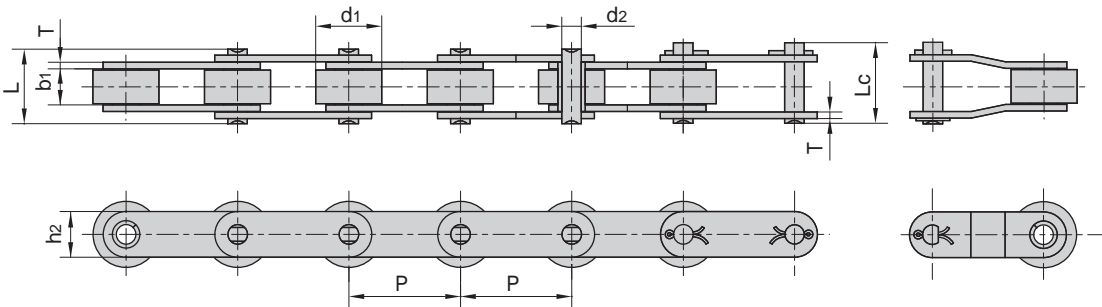

链号 Chain No.	节距 Pitch	滚子直径 Roller diameter	内节内宽 Width between inner plates	销轴直径 Pin diameter	销轴长度 Pin length		内链板高度 Inner plate depth	链板厚度 Plate thickness	极限拉伸载荷 Ultimate tensile strength	平均拉伸载荷 Average tensile strength	每米长重 Weight per meter
	P mm	d1 max mm	b1 min mm	d2 max mm	L max mm	Lc max mm	h2 max mm	T max mm	Q min kN/lbf	Q0 kN	q kg/m
C2050F12	31.75	10.16	9.52	5.08	20.2	21.7	15.0	2.03	18.53/4165	20.0	1.05
C2060F28	38.10	11.91	12.57	5.72	25.9	27.7	20.0	2.42	28.90/6496	32.4	1.40
C2080HF1	50.80	15.88	15.75	7.92	36.2	39.4	23.0	4.00	55.60/12499	61.1	2.49
C2080HF51	50.80	18.00	32.00	7.92	54.0	57.5	24.0	4.00	55.60/12499	61.1	2.66
C220AH-BF1	63.50	19.05	18.90	9.53	43.6	46.9	30.0	4.80	86.70/19490	95.5	3.74
C224AHF2	76.20	27.20	25.22	11.10	-	57.5	35.7	5.60	124.60/280112	139.5	5.78
C224AHLF5	76.20	43.00	25.22	11.10	53.5	-	35.7	5.60	124.60/280112	142.6	7.94
C208BF3	25.40	8.51	7.95	4.45	16.7	-	11.8	1.50	10.00/22480	11.5	0.61
212BHF1	38.10	12.07	11.68	5.94	25.2	28.0	40.8	2.42	31.80/7149	36.6	2.73
C212BF2	38.10	12.07	11.68	5.72	22.5	25.5	35.0	1.85	28.90/6496	33.3	1.88
C212BF9	38.10	12.07	11.68	5.72	22.5	25.2	20.0	1.85	28.90/6496	33.3	1.10
216BF4	50.80	15.88	17.90	8.28	36.1	39.1	21.0	3.70	60.00/13488	66.0	1.80
C216BF1	50.80	15.88	17.02	8.28	36.1	39.1	20.0	4.00/3.00	60.00/13488	66.0	2.01
220BF1	63.50	19.05	19.56	10.19	36.5	37.6	27.0	3.00	65.00/14612	74.7	1.81